



Triple Threat Triple Flail Mower



INNOVATIONS ON THE MOVE

When the challenge arises, Tiger Corporation responds by engineering and designing the best product for the job.

With over 48 years of commitment, giving our customers the best built mowing products on the market, Tiger has designed the new hydraulic driven triple flail pull type mower that is completely self-contained. Each mower can operate independently or a combination of any of the 3 mowing heads simultaneously.

The versatility of this innovative machine allows you to tackle your toughest mowing projects quickly and then simply disconnect the mower and use your tractor to take care of other demanding jobs without keeping the mower attached.



DURABILITY INNOVATION

COMMITMENT

Tiger Features

Productivity. Performance. Power.

This mowing system is great for tackling large areas or wide road ditches quickly and easily. Extreme duty flail mowers can handle grass and brush up to 1" in diameter and boasts a cut path of over 18'8".

Built with adjustable tilt switches located on both wing mowers. Set the switch from 0° to 90°, when head is raised to pre-set angle, the mower shuts down so you can move safely over obstacles in your way.



LEGAL WIDTH AND ROAD READY

QUICK DISCONNECT DRAWBAR HITCH



COMPUTERIZED COOLING FAN



Developed to handle today's mowing challenges with quick disconnects for easy detachment and built with your transportation needs in mind, when mowers are up and locked, unit is legal width, ready to travel from job site to job site safely. Tiger Extreme Duty Flails are designed and built to meet and exceed ANSI and SAE standards.

Minimum Tractor Requirements

Horse Power	85 HP PTO
PTO required	1000 PTO
Drawbar weight	1675 lbs.

Features

Hydraulic System	73.6 GPM (24.5 each section) @ 3,500 PSI
Safety Stop	7 Second Shut Down
Cutter Heads	75" side flails, 90" rear flail
Cut Diameter	1" grass or brush
Cutting Height	1/2" to 6"
Cutter Knife	Forged Heavy Duty
Cutter Shaft	Extreme Duty flail type, 6" diameter
Tilt Switch	Adjustable shut off from 0° to 90°, side heads
Weight	7450 lbs.

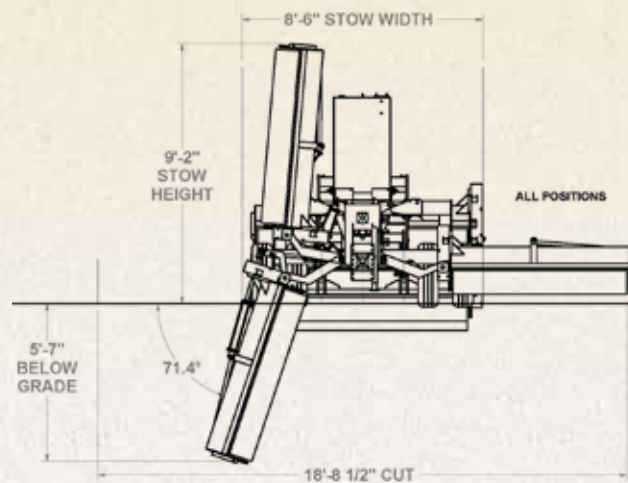

Dealer Info:

Tiger Corporation
 3301 North Louise Ave.
 Sioux Falls, SD, USA 57107
 800.843.6849
 www.tigermowers.com



An Alamo Group® Company
 Specifications are subject to change. Optional equipment may be shown.

Meets All Applicable ANSI / SAE Test Standards.
 © 2016 Tiger Corporation. All Rights Reserved. Printed in the USA.